

33886-1

MOUNT KIT

Dodge Ram 2500/3500 Gasoline	2010 - ___
Dodge Ram 2500/3500 Diesel	2010 - ___

Installation Instructions

⚠ CAUTION

Read this document before installing the snowplow.

⚠ CAUTION

See your sales outlet/website for specific vehicle application recommendations before installation. The online selection system has specific vehicle and snowplow requirements.

SAFETY DEFINITIONS

⚠ WARNING
 Indicates a potentially hazardous situation that, if not avoided, could result in death or serious personal injury.

⚠ CAUTION
 Indicates a potentially hazardous situation that, if not avoided, may result in minor or moderate injury. It may also be used to alert against unsafe practices.

NOTE: Indicates a situation or action that can lead to damage to your snowplow and vehicle or other property. Other useful information can also be described.

WARNING/CAUTION & INSTRUCTION LABELS

Become familiar with and inform users about the warning and instruction labels on the back of the blade.

NOTE: If labels are missing or cannot be read, see your sales outlet.

Warning/Caution Label

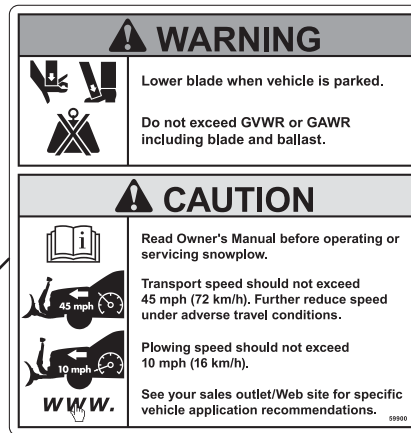

Instruction Label

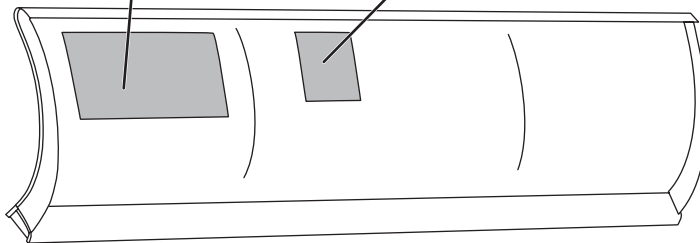

SAFETY PRECAUTIONS

Improper installation and operation could cause personal injury and/or equipment and property damage. Read and understand labels and the Owner's Manual before installing, operating, or making adjustments.

⚠ WARNING

Lower the blade when vehicle is parked. Temperature changes could change hydraulic pressure, causing the blade to drop unexpectedly or damaging hydraulic components. Failure to do this could result in serious personal injury.

⚠ WARNING

The driver shall keep bystanders clear of the blade when it is being raised, lowered, or angled. Do not stand between the vehicle and the blade or within 8 feet of a moving blade. A moving or falling blade could cause personal injury.

⚠ WARNING

Keep hands and feet clear of the blade and A-frame when mounting or removing the snowplow. Moving or falling assemblies could cause personal injury.

⚠ WARNING

Do not exceed GVWR or GAWR including the blade and ballast. The rating label is found on the driver-side vehicle door cornerpost.

⚠ WARNING

To prevent accidental movement of the blade, always turn the control OFF whenever the snowplow is not in use. The power indicator light will turn OFF.

⚠ WARNING

Remove blade assembly before placing vehicle on hoist.

⚠ CAUTION

Refer to the online selection system for minimum vehicle recommendations and ballast requirements.

PERSONAL SAFETY

- Remove ignition key and put the vehicle in park or in gear to prevent others from starting the vehicle during installation or service.
- Wear only snug-fitting clothing while working on your vehicle or snowplow.
- Do not wear jewelry or a necktie, and secure long hair.
- Wear safety goggles to protect your eyes from battery acid, gasoline, dirt, and dust.
- Avoid touching hot surfaces such as the engine, radiator, hoses, and exhaust pipes.
- Always have a fire extinguisher rated BC handy, for flammable liquids and electrical fires.

FIRE AND EXPLOSION

⚠ WARNING

Gasoline is highly flammable and gasoline vapor is explosive. Never smoke while working on vehicle. Keep all open flames away from gasoline tank and lines. Wipe up any spilled gasoline immediately.

Be careful when using gasoline. Do not use gasoline to clean parts. Store only in approved containers away from sources of heat or flame.

CELL PHONES

A driver's first responsibility is the safe operation of the vehicle. The most important thing you can do to prevent a crash is to avoid distractions and pay attention to the road. Wait until it is safe to operate Mobile Communication Equipment such as cell phones, text messaging devices, pagers, or two-way radios.

VENTILATION

⚠ WARNING

Vehicle exhaust contains lethal fumes. Breathing these fumes, even in low concentrations, can cause death. Never operate a vehicle in an enclosed area without venting exhaust to the outside.

NOISE

Airborne noise emission during use is below 70 dB(A) for the snowplow operator.









VIBRATION

Operating snowplow vibration does not exceed 2.5 m/s² to the hand-arm or 0.5 m/s² to the whole body.

TORQUE CHART

⚠ CAUTION

Read instructions before assembling. Fasteners should be finger tight until instructed to tighten according to the torque chart. Use standard methods and practices when attaching snowplow, including proper personal protective safety equipment.

Recommended Fastener Torque Chart					
Inch Fasteners Grade 5 and Grade 8					
Size	Torque (ft-lb)		Size	Torque (ft-lb)	
	 Grade 5	 Grade 8		 Grade 5	 Grade 8
1/4-20	8.4	11.9	9/16-12	109	154
1/4-28	9.7	13.7	9/16-18	121	171
5/16-18	17.4	24.6	5/8-11	150	212
5/16-24	19.2	27.3	5/8-18	170	240
3/8-16	30.8	43.6	3/4-10	269	376
3/8-24	35.0	49.4	3/4-16	297	420
7/16-14	49.4	69.8	7/8-9	429	606
7/16-20	55.2	77.9	7/8-14	474	669
1/2-13	75.3	106.4	1-8	644	909
1/2-20	85.0	120.0	1-12	704	995
Metric Fasteners Class 8.8 and 10.9					
Size	Torque (ft-lb)		Size	Torque (ft-lb)	
	 Class 8.8	 Class 10.9		 Class 8.8	 Class 10.9
M6 x 1.00	7.7	11.1	M20 x 2.50	325	450
M8 x 1.25	19.5	26.9	M22 x 2.50	428	613
M10 x 1.50	38.5	53.3	M24 x 3.00	562	778
M12 x 1.75	67	93	M27 x 3.00	796	1139
M14 x 2.00	107	148	M30 x 3.50	1117	1545
M16 x 2.00	167	231	M33 x 3.50	1468	2101
M18 x 2.50	222	318	M36 x 4.00	1952	2701
These torque values apply to fasteners except those noted in the instructions.					

INSTALLATION INSTRUCTIONS

NOTE: For easier assembly and installation, the vehicle and all snowplow components should be on a smooth, level, hard surface, such as concrete.

1. Remove the lower plastic portion of the bumper. Save all parts for reinstallation.

Vehicles equipped with tow hooks will need the tow hooks and outer tow hook brackets removed. These cannot be reinstalled with the snowplow mount in place. Retain the tow hooks, brackets, and fasteners for reinstallation if the mount is removed. The inner tow hook brackets can remain in place.

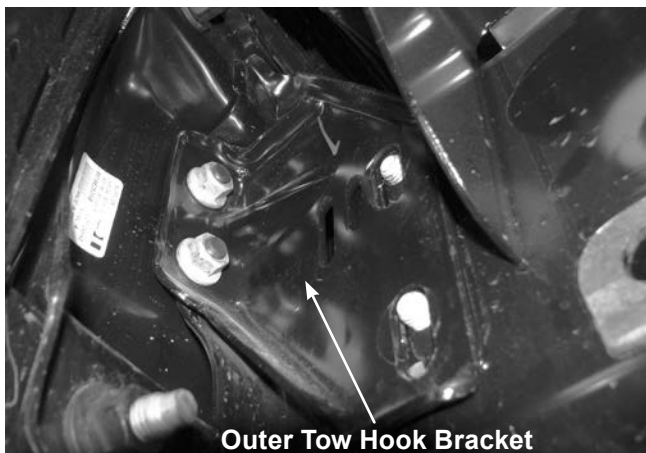

2. Remove the compatibility brackets from the frame, if so equipped (see illustration below). Save the brackets and hardware for the vehicle owner.

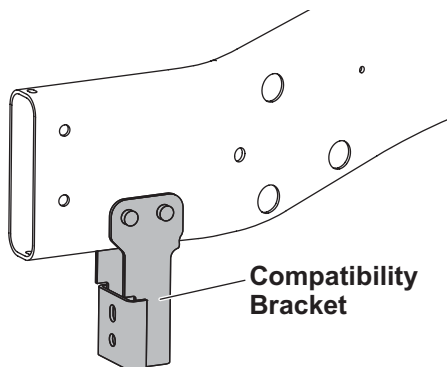

3. Remove the nuts from the bumper fastener assembly on both sides of the vehicle. For both driver-side and passenger-side mounts, align the forward mount holes with the protruding cap screws and guide the mounts onto their respective fastener assembly. Loosely fasten by reinstalling the original nuts.

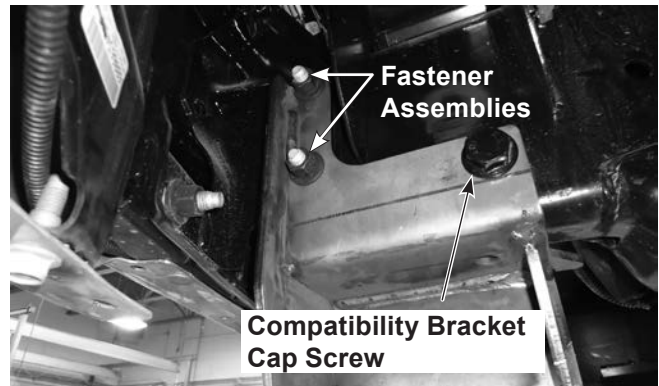

If the vehicle was equipped with compatibility brackets, reinstall one of the original bracket cap screws through the rear hole of each mount and the existing hole in the vehicle frame. Secure with the original nut.

- Lower the stabilizer bar by removing the two cap screws located on the bottom of the frame rail on each side of the vehicle.



Position a stabilizer bracket between the bottom of the frame rail and the stabilizer bar retainer for both sides, facing inward as shown below.

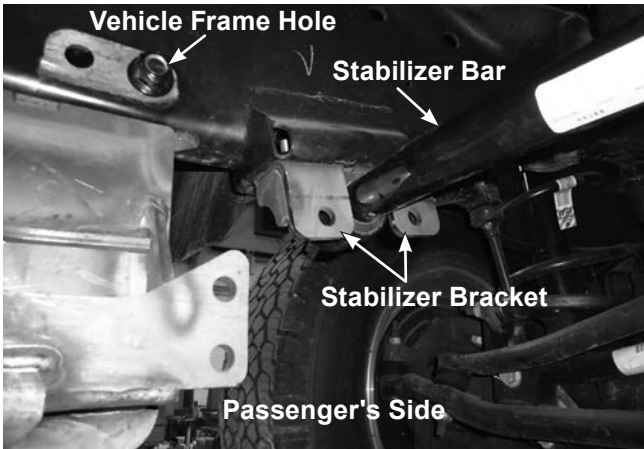

Loosely fasten with the M10 cap screws provided.

NOTE: Thread provided M10 cap screws into the underside vehicle frame weld nuts. Cross threading will strip these nuts or fail nut weld.

- Using four 1/2" x 1-1/2" cap screws and 1/2" locknuts, loosely fasten a thrust arm to both mounts, connecting the stabilizer brackets and the rear mount holes.



Thrust arms are interchangeable and can install on either side of the vehicle. There is no left or right side-specific part.

Be sure to insert the cap screws through the stabilizer brackets pointing inward from outside the vehicle to ensure access to the M10 cap screws for later tightening.

- Install the cross bar with the horizontal leg on the bottom using four 1/2" x 1-1/2" cap screws and 1/2" locknuts as shown below. Keep fasteners loose for now.

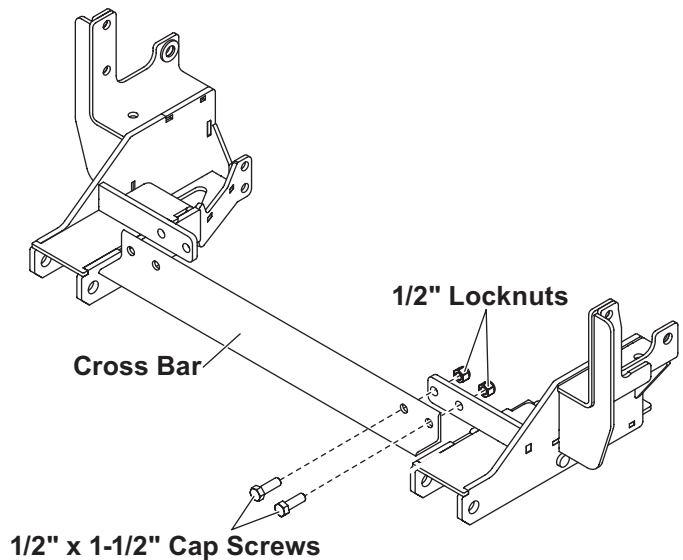

⚠ CAUTION

Before drilling any holes, check both sides of the material for any wires, fuel lines, fuel tanks, etc., that may be damaged by drilling.

7. **On vehicles without compatibility brackets:** Clamp the rear of each mount tightly against the bottom of the truck frame. Using the bottom mount hole as a guide, drill a $17/32$ " diameter hole through the bottom of the frame rail.
8. Trim the handle of a $1/2$ " x $1-1/2$ " cap screw with handle to $1-1/2$ " long, as shown. Insert it into the opening in the side of the frame rail and through the $17/32$ " drilled hole in the bottom of the frame. Loosely fasten with a $1/2$ " locknut.



Using the $11/16$ " diameter mount holes as guides, drill an $11/16$ " diameter hole through the outer wall of each frame rail.

Insert a $5/8$ " nut with handle through the opening in the side of each frame rail and align with the drilled holes. For each of the mounts, insert a $5/8$ " x $1-1/2$ " cap screw through both the mount hole and drilled hole in the frame rail, and thread into the $5/8$ " nut with handle.

9. Trim any portion of the handles protruding through the frame openings.
10. **For all vehicles:** Measure the distance between the mounts as shown below. This distance should be $30-7/16$ " \pm $1/8$ ". Once the proper distance is achieved, tighten the cross fasteners according to the torque chart.

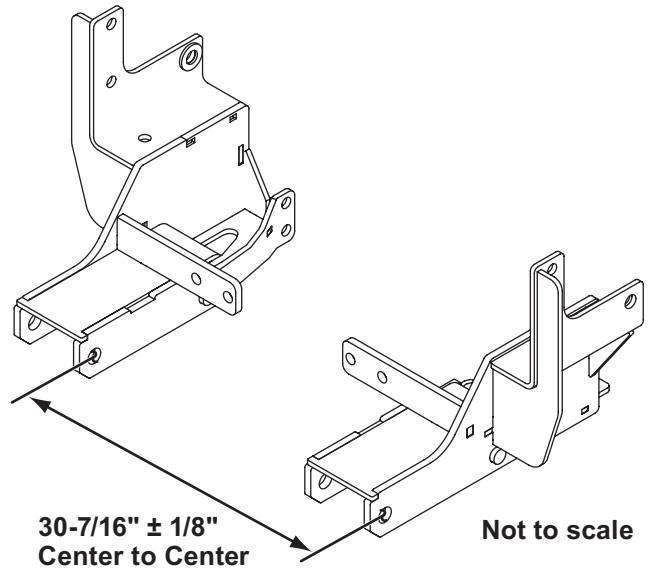

Tighten the M10 stabilizer bracket cap screws and all remaining fasteners according to the torque chart. Start at the front of the mount and work rearward.

11. Notch the lower plastic portion of the bumper as needed to accommodate the snowplow mounts and snowplow. Reinstall using original vehicle fasteners.

NOTE: After five to ten hours of snowplow usage, retorque all mount assembly fasteners.

The company reserves the right under its product improvement policy to change construction or design details and furnish equipment when so altered without reference to illustrations or specifications used. This equipment manufacturer or the vehicle manufacturer may require or recommend optional equipment for snow removal. Do not exceed vehicle ratings with a snowplow. The company offers a limited warranty for all snowplows and accessories. See separately printed page for this important information.

Printed in U.S.A.
